

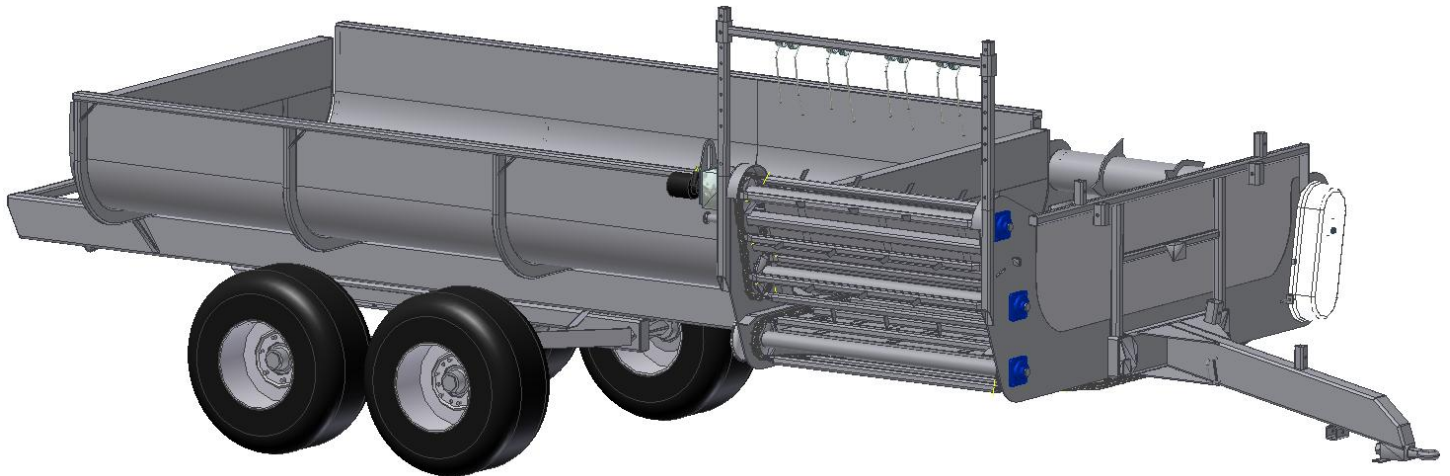

Manufacturers of Agricultural Equipment



Specifications – Multi Feeder 4B



FEEDOUT TYPE:	Via the fixed elevator that has an endless chain with 3" spikes that tear at the material, ensuring that a well aerated row is presented. Priority oil flow to the elevator motor ensures maximum torque, this can be set at the block - Options include - hydraulic tilting elevator - round bale shredder rota - electric over hydraulic controls
BALE TYPES:	Will feed out all square bales and pit silage over the elevator and if round bales are present the optional shredder rota on nearside is recommended
CROP TYPES:	Silage bales, hay & straw, all types of square bales and both grass and maize silage
BODY TYPE:	Bath tub one piece monocoque body, with top RHS shock rails
ELEVATOR ANGLE:	Fixed angle as standard with optional tractor controlled elevator with either 60° or 90° angle options
4' ROUND BALES:	4 up to 6' diameter
4' x 3' SQUARE BALES:	4 at 7' long (as a single layer)
CUBIC CAPACITIES:	7m ³ level, 12m ³ potential approx

KGS CAPACITY:	4,800kgs
BODY LENGTH:	7,000mm
OVERAL LENGTH:	8,450mm
SIDE DEPTH:	600mm
BODY WIDTH ID:	2,100mm
OVERAL WIDTH:	2,640 without shredder. 2940mm with shredder
AXLE SINGLE:	70mm / 6 stud brakeless
SINGLE WHEELS:	400 / 60 x 15.5
AXLE TANDEM:	60mm / 6 stud brakeless
TANDEM WHEELS:	11.5 x 15.3
SUSPENSION:	Tandem walking balance beam
LOADING HEIGHT:	1,500mm approx (subject to wheels)
CHASSIS:	200 x 100 x 5mm fully welded chassis
DRAW BAR LENGTH:	1,450mm as standard with option for 1,750mm for wide track tractor or 2,050mm for tractors running dual wheels
FLOOR THICKNESS:	3mm mild steel
TOW EYE:	Fixed eye as standard or Optional swivel eye
HEADBOARD:	Fixed headboard with 3mm agrimesh for maximum visibility
FINISH/COLOUR:	Blasted, etch base zinc high build primer then dried. Followed by 2 x gloss coats of gloss paint Agmech Yellow.
OPTIONS:	Dicuss your individual requirements with your dealer as a range of options are available.

NOTES