

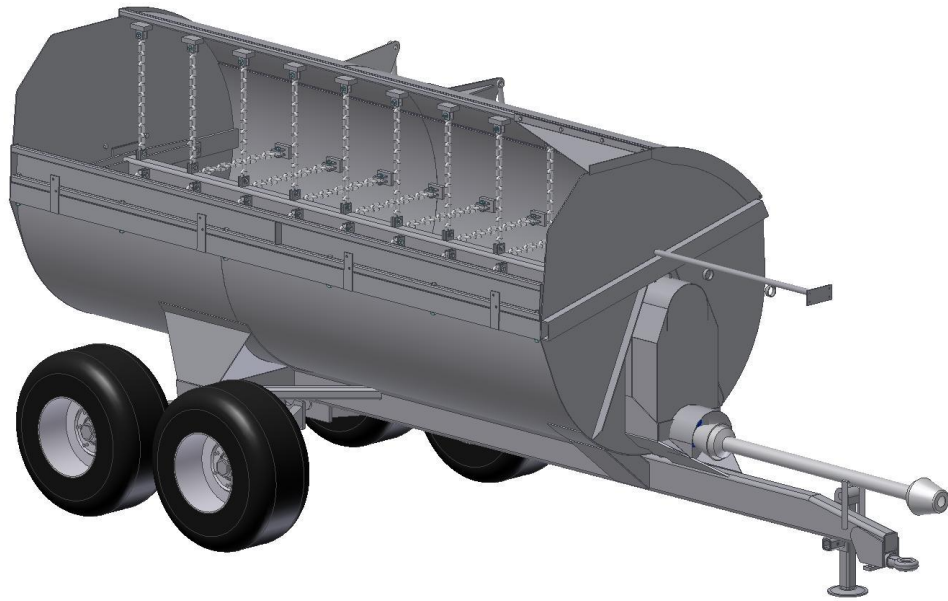

Manufacturers of Agricultural Equipment



Specifications - MM 800T



BODY TYPE:	Fully welded monocoque body
CAPACITY TONNES	10 tonnes
CUBIC CAPACITY	8.0m ³
LIQUID CAPACITY	6,500 litres (with 200mm hungry board fitted)
BODY LENGTH	3,900mm
OVERAL LENGTH:	5,650mm
BARRELL DIAMETRE	1.60mØ barrel
OVERAL WIDTH:	2,400mm depending on wheels
OVERALL HEIGHT	2,250mm depending on wheels
AXLE SINGLE	X

AXLE TANDEM	70mm / 6 stud
WHEELS ON SINGLE	X
WHEELS ON TANDEM	400 / 60 x 15.5 - 14 ply
SUSPENSION	Oscillating tandem
LID	Hydraulic optional
MUDGUARDS	Optional
CHASSIS	200 x 100 x 9 RHS
BARRELL SPEC	5mm barrel with 6mm end plates
ROTA SPEC	100 x 100 x 9 RHS with 40 x 13mm chain
GEARBOX	3 : 1 reduction on 3/4" duplex drive
PTO	Wide angle PTO with 6 spline both ends
DRAW BAR SUPPORT	80mm jack
TOWING EYE	Swivel 43mm eye
FINISH	Blasted, heavy coat of primer then 2 x gloss coat
COLOUR	Agmech Yellow / charcoal / wheels white
OPTIONS	Discuss your individual requirements with your dealer as a range of options are available.

NOTES