

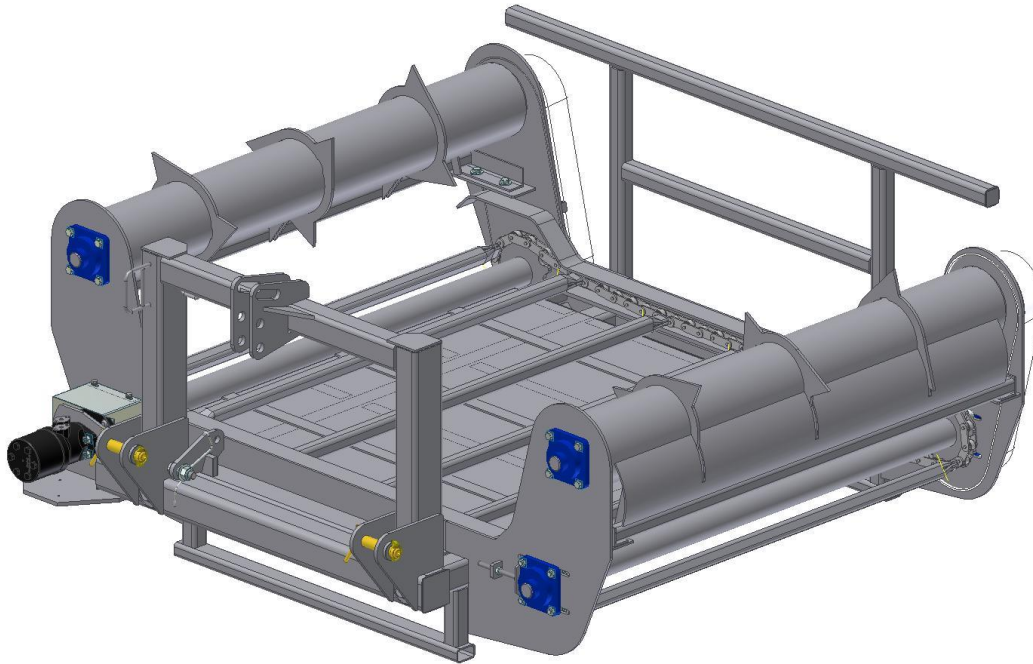

Manufacturers of Agricultural Equipment



Specifications – Twin Shredder TS



FEED OUT TYPE:	Bi directional chain - teasing rota shredder on near side - high curve on off side
BALE TYPES:	Round tight Bales
CROP TYPE:	Silage / Hay / Straw bales
HYDRAULIC CONTROL:	1 x double acting
CAPACITIES IN KGs:	1,100kgs
4' ROUND BALES:	1
BODY LENGTH:	2,400mm
BODY WIDTH:	2,300mm
TARE WEIGHT:	710kgs

CHASSIS:	75mm x 75mm 400 grade RHS fully welded to 4711 standard
FLOOR THICKNESS	1.6mmm steel floor with nominal bracing underneath as well as rub bars on top
HEADBOARD	Pipe Headboard
OIL REQUIREMENT	Minimum of 32 litres / minute
LOADING	75mm x 75mm 400 grade RHS fully welded to 4711 standard
FINISH	Blasted, zinc base primer, 2 x gloss coats
COLOUR	Agmech Yellow on body with charcoal components and white comb
OPTIONS	Discuss your individual requirements with your dealer as a range of options are available.

NOTES