

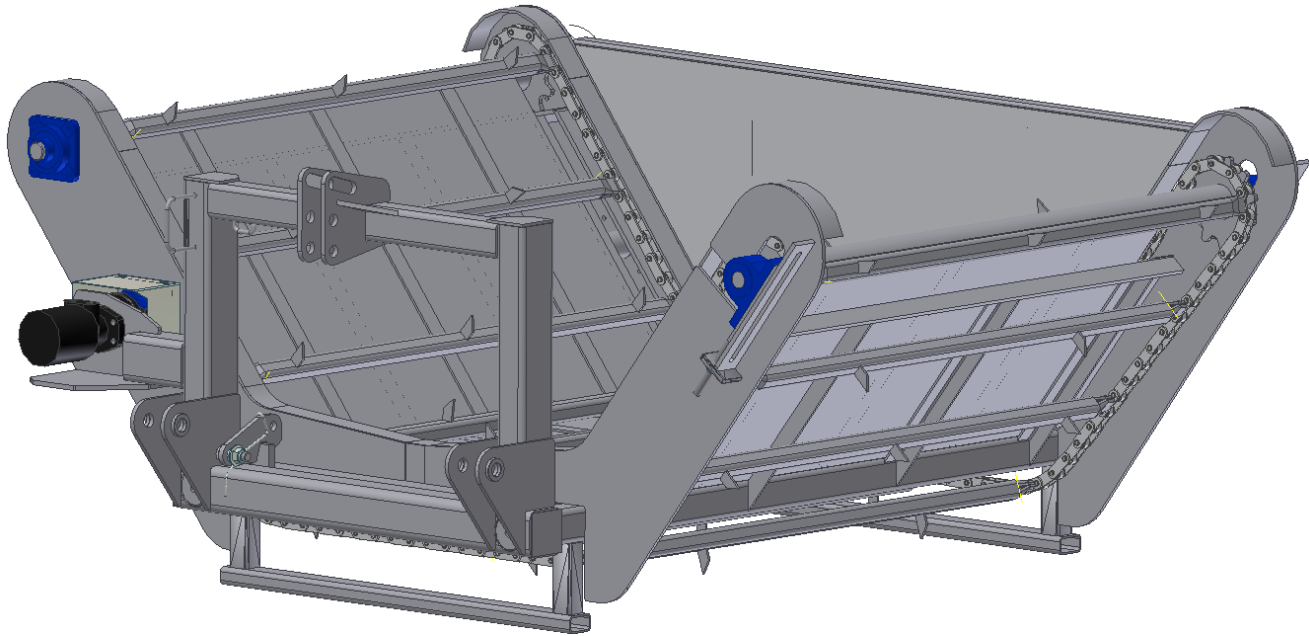

Manufacturers of Agricultural Equipment



Specifications – Linkage Double Curve - DC



FEED OUT TYPE:	Bi directional chain - on symetrical high curve - ideal for all chopped round bales
BALE TYPES:	Round chopped Bales
CROP TYPE:	Silage bales
HYDRAULIC CONTROL:	1 x double acting
CAPACITIES IN KGs:	1,100kgs
4' ROUND BALES:	1

BODY LENGTH:	2,400mm
BODY WIDTH:	2,300mm
TARE WEIGHT:	540kgs
CHASSIS:	75mm x 75mm 400 grade RHS fully welded to 4711 standard
FLOOR THICKNESS	1.6mm steel floor with nominal bracing underneath as well as rub bars on top
HEADBOARD	Mesh Headboard
OIL REQUIREMENT	Minimum of 32 litres / minute
LOADING	75mm x 75mm 400 grade RHS fully welded to 4711 standard
FINISH	Blasted, zinc base primer, 2 x gloss coats
COLOUR	Agmech Yellow on body with charcoal components and white comb
OPTIONS	Discuss your individual requirements with your dealer as a range of options are available.

NOTES