

AGMECH MULTI FEEDER



MANUFACTURERS OF QUALITY MACHINERY

**THIS MANUAL COVERS THE FOLLOWING RANGE OF
AGMECH MULTI FEEDERS:**

**3B
4B
5B
6B**

OPERATIONAL MANUAL

Agmech Ltd
PO BOX 16 590, HORNBY
CHRISTCHURCH
NEW ZEALAND

PHONE ++64 (03) 344 1322
FAX ++64 (03) 344 5659



Introduction	5
Safety.....	7
Attaching to the tractor.....	9
Attaching to the tractor.....	10
Loading the feeder.....	12
Round bales	12
Square bales.....	12
Pit silage	12
Feeding out.....	13
Round bales	13
Square bales.....	13
Pit silage	13
Maintenance	14
Periodic servicing.....	14
Before daily operation:.....	14
Every 50 hours	14
Every six months:.....	15
Annually/before and after storage:.....	15
Adjusting the floor chains	16
Adjusting the shuttle chain.....	17
Adjusting the elevator chain.....	17
Adjusting the elevator chain.....	18
Fixed elevator	18
Folding elevator.....	18
Spare parts	19

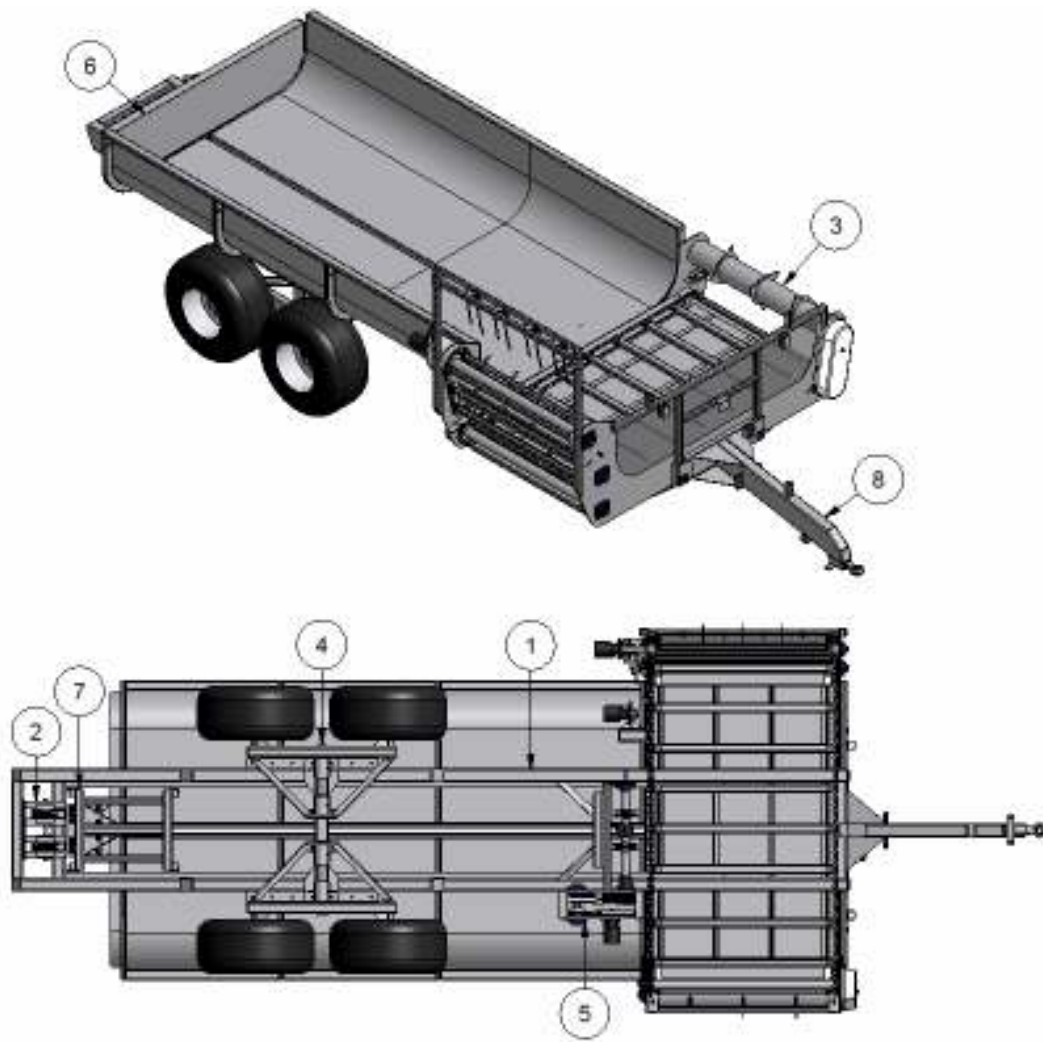

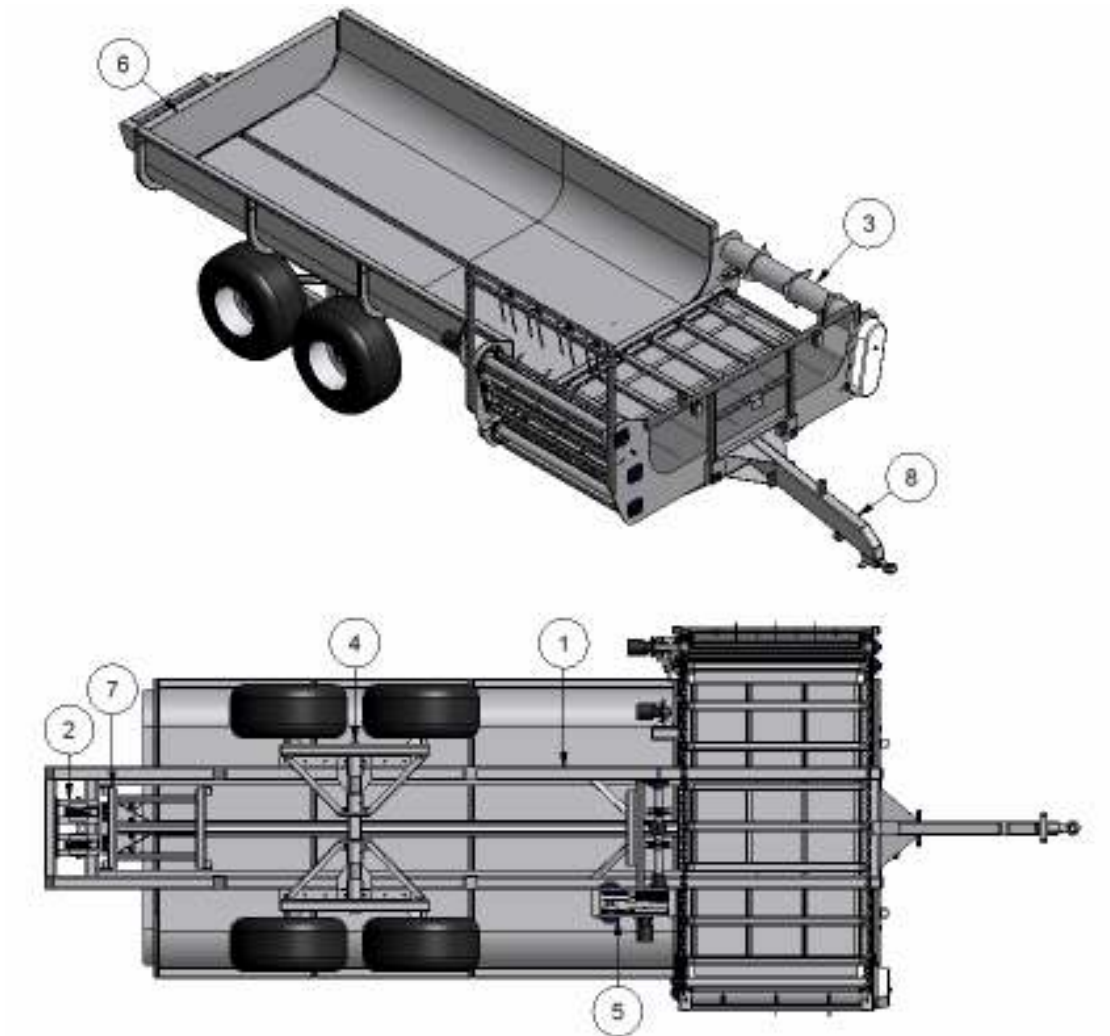

.....	20
Troubleshooting	21
Terms and conditions of manufacture and supply	23

Introduction

Thank you for considering Agmech for your feed out requirements, we are very pleased to be able to offer you our Multi feeder for square bale, round bale and pit silage feeding. These feeders are capable of feeding out fine chop silage, all types of round bales and all square bales. We have introduced the Multi-feeder into the feeder range as a simple to use machine for those customers that require the need to be able to handle all types of feed

What we have aimed to achieve is:-

- A functional machine that exceeds your expectation in the field.
- The engineering, design and aesthetics of the machine prove to give you optimum longevity.
- The price ensures that the unit is competitive whilst considering spec for spec.
- The optional equipment ensures all customers requirements are covered

For all farmers that buy in feed, these machines give you the peace of mind that you will be able to feed out anything. The tub body design offers a low drag friction factor yet adds phenomenal strength to the monocoque design. They are incredibly well made using RHS steel ensuring maximum longevity of the structural components. So whether its chopped silage, square bales or rota cut round bales you can rest assured that the Multi-feeder will perform.

Unique Features Very well priced for its abilities.

Handles all feed types

Speed control on the floor chain with a sequencing valve to ensure an even feed out.

Low centre of gravity.

Optimum ground clearance.

Bi directional floor chain with RHS bars.

Fully welded 200 x 100 section RHS chassis.

Straight drawbar for maximum turning circle.

Large 40mm bearings and shafts on shredders 50mm on shuttle drive.

Full steel floor welded to RHS frame.

2 wire hose on all hydraulics.

Large axle and floatation wheels.

High torque hydraulic motors.

All Agmech Multi - feeders have the ability for the floor chain to be slowed invariably, this is ideal for square bales that generally require a level of agitation to break the wads into a well presented row. Primarily this is done via a simple hydraulic valve fitted to the headboard that the operator can easily access to make immediate alterations to speed, secondly there is an adjustable tine rail retarder bar fitted above the elevator that assists in separating the wads.



Dual axle positioning (depending on model) allows for the feeder to ensure optimum tow eye weight is transferred to the tractor whilst maintain a good manoeuvrability. It also allows for a good selection of wheel options to be offered from 11.5/80 x 15.3 up to 500/45 x 22.5 depending on model

The 500cc shuttle gearbox drive motor transfers torque via a 9:1 ratio giving nearly 10 tonnes of thrust to the shuttle, this ensures even the heaviest of bales will transfer to the feed out chamber. The shuttle drive line is protected by a factory set cross line relief valve. The floor chamber has a 400cc motor with a 3:1 ratio maximising the motors optimum working band which eliminates 'cavitating'. This works in conjunction with the elevator via a sequencing valve effectively giving an automatic feed-out. The elevator speed is direct via the block which then allows for the elevator to stop automatically when feeding over the shredder.

Hydraulic requirements for standard feeders:-

Tease elevator & Floor chains = 1 x double remote

Shuttle = 1 x double remote

Please note many of the multi feeders are built with hydraulic folding elevators which help the operator get the optimum speed from the Multi feeder and are generally fitted with electric over hydraulic controls that bring the 4 functions back to a 2 x remote requirement.

Safety

Before operation of this machine, please ensure yourself and all additional operators are trained in the correct operating procedures and aware of all safety requirements and potential hazards.

General Safety Precautions:

1. Take all practical steps to ensure the safety of yourself and others.
2. Where possible, read and understand the applicable Health and Safety regulations for your area.
3. Before attempting to operate the machine the operator must be fully trained and familiar with the safe working limits, controls and operator instructions as detailed in this manual.
4. Ensure all guards remain in place during operation.
5. Keep clear of all moving parts and be aware of pinch points.
6. Do not perform any maintenance or repairs without shutting off the tractor beforehand.
7. Exercise caution whenever working with hydraulics.
8. You must eliminate if practicable, or otherwise isolate or minimise all significant hazards and report to your Safety Officer or Supervisor IMMEDIATELY every hazard or safety problem that you notice.
9. If you witness an accident or incident where someone was or could have been injured, you MUST report it as soon as you can.
10. For serious accidents the entire accident scene must not be interfered with until authorised by an inspector from the appropriate Health and Safety Authority, unless absolutely necessary to save life, property, etc.
11. If you received an injury while at work it MUST be reported immediately to your Supervisor or Safety Officer. The accident will be recorded on either a form for Record of Accident/Serious Harm or a form for Minor Accident or Near Miss Report. If a work injury is not reported on the day the injury occurs it may not be accepted as a work related injury and which could affect your work accident insurance.

Specific safety hazards:

Failure to comply with the following safety requirements could result in serious personal injury or loss of life.

- When attaching the feeder to the tractor, nobody must be in the area between the tractor and the feeder unless the tractor is in neutral with the park brake securely on.
- Do not remove the drawbar pin without the jack down and chocks either side of the wheels or the retractable foot down. .
- No person may be permitted to ride on the machine.
- The guards on each drive chain and the drive coupling must remain in place at all times during operation of the feeder. **The feeder must not be operated without these guards in place.**
- Keep clear of the drive and floor chains at all times during operation. Shut the tractor engine off before making any adjustments to the feeder.
- Keep clear of shredder rotors (if fitted) at all times during operation.
- Keep clear of folding extension.
- Keep clear of shuttle at all times.

Do not operate without all guards in place

Keep clear of shuttle

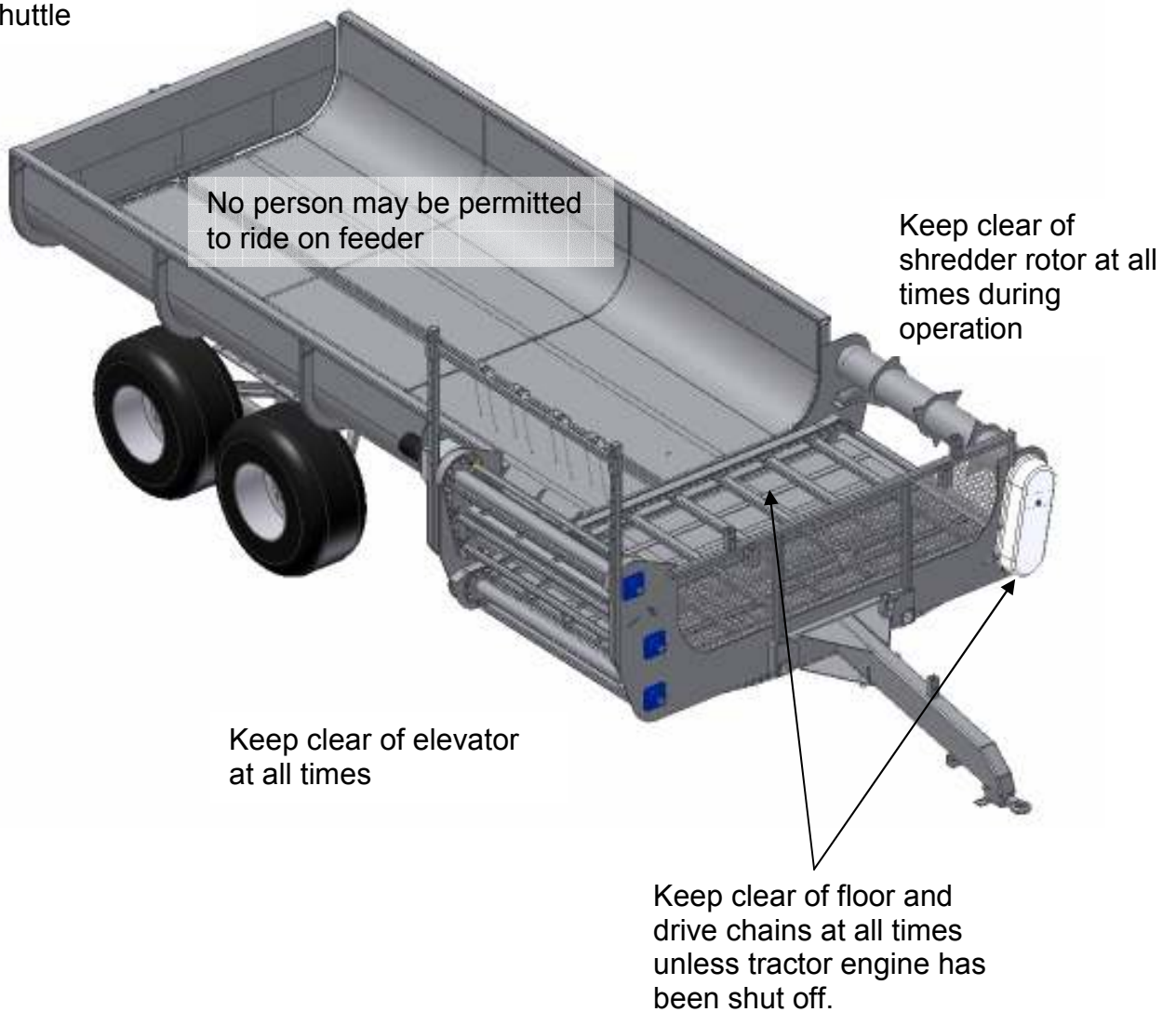

Attaching to the tractor

Once the contents of this manual have been read and understood, familiarize yourself with the feeder and each of the components before selecting a tractor.

When selecting a tractor to operate the feeder please consider the following;

1. The terrain and conditions you will be operating in.
2. The tare weight of the feeder you are using
3. The weight of the material you are about to feed out
 - Approximate payload:
 - 800kgs per silage bale
 - 500kgs per hay bale
4. The tare weight of the tractor.
5. Whether the towing tractor is fitted with foot pedal braking.
6. Whether you will be travelling on a public highway and therefore the local regulations you will be required to follow.

All of the above factors are relevant to ensure safe and successful operation of the feeder.

Connecting up the feeder

The bale feeder will be fitted with a fixed tow eye as standard or a swivel/variable height tow eye as optional. These tow eyes are rated to European standard of origin and comply with all relevant T.U.V. and D.I.N. compliance codes.

Important: Please ensure that you have studied the tractor manufacturer recommended drawbar load rating and the feeder is not going to exceed this.

Assuming that the tractor is fitted with the standard double clevis type drawbar then it is good practice to ensure that the tractor and feeder are permanently attached by fitting cross over safety chains (this may be enforced in some countries), these are not supplied as standard but can be purchased from the manufacturer.

It is also favourable to fit a spacer bush (if required) between the tow eye and drawbar pin, this will prevent un-necessary drawbar pin wear as well as increasing operator comfort by eliminating fore and aft banging. These bushes are not supplied as standard but can be purchased from the manufacturer.



For attaching the feeder to a standard double clevis drawbar;

1. Set the height of the feeder drawbar to match the selected tractor using the supplied jack on the feeder.
2. Make sure you have a suitable drawbar pin and lynch pin/R-clip to fit pin.
3. With the tractor drawbar in the central position, reverse up to the feeder until the drawbar and feeder tow eye overlap.
4. Fit the drawbar pin and spacer bush if required, lock the drawbar pin in place using a pin or clip to prevent the drawbar pin from jumping out during operation.
5. Fit the safety chains between the tractor and feeder drawbar, ensuring there is sufficient slack in each chain when under full steering lock.
6. Wind the jack fully in, pull the pin holding the jack to the drawbar and transfer the jack to the transport position in front of the bale chamber. Ensure you lock the jack in place using the pin before moving off.
7. Connect up the hydraulic hoses to the outlets on the tractor, it is often preferred to connect the two hoses controlling the feed out chamber to the number 1 remote and then control the loading operation using the number 2 remote. **Make sure each coupling is clean before connecting.**

Loading the feeder

The Multi feeder range has the ability to handle both round and square bales together with pit silage. The loading sequence will therefore be determined by the type of feed and the loader attachment but the following guidelines may be useful in ensuring you get the most from your feeder.

Round bales

1. Ensure shuttle is in rear most position.
2. If using same tractor to load, disconnect the tractor from the feeder- make sure the retractable foot is in the down position.
3. Remove the net wrap and plastic from the bale. Ensuring you dispose of the waste responsibly.
4. The bales can be loaded onto the feeder in two different ways;
 - a. Either pierce the round of the bale and load over the side of the feeder.
 - b. Or pierce the end of the bale and load over the rear shuttle. Push the bales toward the front of the feeder as you go, the retractable foot will prevent the feeder moving forward.

Square bales

1. Ensure shuttle is in rear most position.
2. If using same tractor to load, disconnect the tractor from the feeder- make sure the retractable foot is in the down position.
3. Remove the plastic from the bale, the twine can be removed once the bale has been loaded. Dispose of the plastic responsibly.
4. Square bales feed out the easiest if positioned lengthwise across the feeder.
5. Pierce the side of the bale, it makes it easier to remove the twine from the bale if the knots are on the top edge of the bale.
6. Load the bales over the rear shuttle, pushing the bales towards the front of the feeder as you go. The retractable foot will prevent the feeder moving forward.
7. Once loaded, the easiest way to remove the twine is to cut all the twine on the outside of the knots, the twine can then be pulled from the bale.

Pit silage

1. Ensure shuttle is in rear most position.
2. If using same tractor to load, disconnect the tractor from the feeder- make sure the retractable foot is in the down position.
3. Pit silage is most easily loaded with either silage forks or a grab over the side of the feeder.

Feeding out

The multi feeder is able to feed all types of round and square bales together with pit silage or a combination of each. The feed out process will then have to be modified to suit the combination of feed. The feed out operation is controlled by the single hydraulic outlet, which can be set in detent for continuous feeding or alternatively controlled by the operator for a start – stop operation. The following guidelines may be useful for achieving the best possible results from your feeder.

Important: it is advised that any net wrap or baler twine is removed prior to feed out as it can find its way into bearing seals and sprockets causing damage.

Round bales

1. Chopped round bales will feed out the best if the side elevator is positioned close to vertical.
2. The floor speed should be reasonably high to tease the bale apart.
3. Alternatively if fitted with a tease shredder, this can be used for tight long chop bales to give a fluffy feed row which promotes the flow of air through the material.
4. Once the bale in the chamber has been feed out, bring the shuttle forward to transfer the next bale to the chamber.

Square bales

1. The teaser tines can be adjusted to suit the type of bale and the size of the required feed row.
2. The floor chain speed can be reduced, using the adjuster on the front of the headboard, a slower floor speed will allow the side elevator to pull the bale apart giving an even feed row.
3. The side elevator can also be adjusted to give the desired feed row.
4. Once the bale in the chamber has been feed out, bring the shuttle forward to transfer the next bale to the chamber.

Pit silage

1. The floor speed can be adjusted to change the size of the feed row. A high floor speed will give a heavy feed row whereas a low floor speed will give a light feed row.
2. The side elevator can also be adjusted to suit the type of silage and the desired feed row, the elevator at a high angle will give a light feed row whereas if the elevator is lowered the feed row will be heavier.
3. Once the amount of feed in the feed out chamber has dropped bring the shuttle forward to transfer more material to the chamber.

Maintenance

The following guidelines if followed correctly will allow for many years of successful operation.

Please check all Nuts & bolts prior to use, then after 8 hours of use and finally after 100 hours of operation, this will ensure everything will remain tight. Then seasonal servicing will be sufficient to maintain the feeder.

Periodic servicing

Greasing intervals have been based on a standard hand lever grease gun. **Do not use an air powered grease gun.** General multipurpose grease is sufficient although the bearings would benefit from dedicated bearing grease.

Before daily operation:

- Visually inspect all components of the feeder for wear or damage, ensuring there is no material build up around sprockets or bearings.
- Check the tyres for wear, damage and tire pressure.

Every 50 hours

- Grease the bearings on each end of the cross shafts in the feed chamber. One single pump is sufficient, **Do not over grease**, excess grease can damage the seals and significantly reduce the life of the bearings.
 - 6 for models folding elevator and without shredder.
 - 8 for models with either folding elevator and shredder or fixed elevator without shredder.
 - 10 for Multi with fixed elevator and shredder.
- *Multi with folding elevator:* Grease the two pivot points on the bottom shaft of the elevator
- Lubricate the shredder, floor and shuttle drive chains with an oil and diesel mix, easily applied with a paint brush. The shredder drive chains can be easily accessed by removing the plastic covers on the front of each feeder. The shuttle and floor drive chains can be accessed by removing the covers on the respective drive units.
- Lubricate the floor and elevator chains with an oil and diesel mix.
- Grease the wheel bearings if grease nipples are fitted.
- *Swivel tow eye if fitted:* Grease and check for excessive movement.
- Grease the jack (if fitted with grease nipples)
- Check the tension of the floor (1) and elevator chains (2).
- Grease the tandem assembly, 4 grease nipples underneath and check for excessive wear in the pins and bushes.
- Grease the rear shuttle chain idler sprockets.

- Grease the 4 bearings on the shuttle chain drive.
- Check the tension of the shuttle drive chain (3) and the main shuttle chain (4).
- Check all hydraulic motors are secure and there are no hydraulic oil leaks or major abrasions to the hoses.
- Check the condition of the four nylon support blocks on the shuttle.

Every six months:

- Check the free play in the wheel bearings.
- Check the condition of all bearings.
- Check the tow eye for excessive wear.
- Check the drive chains are correctly tensioned.

Annually/before and after storage:

- Lubricate the drive, elevator and floor chains with an oil and diesel mix, easily applied with a paint brush.
- Grease the bearings on each corner of the feed out chamber.
- Visually inspect all components of the feeder.
- Check the tension of the floor, shuttle and drive chains.
- Check the hydraulic motors are secure and there are no leaks or cuts in the hoses.
- Check the hydraulic ram for scoring or leaks from the seal (folding elevator models only).
- If storing for long periods of time, it is advisable to jack the rear of the feeder up, so the wheels are free of the ground and support the tandem unit with suitable blocks of wood.

Adjusting the floor chains

If the distance between the underside of the floor and the floor chains exceeds 80-100mm adjust the floor chains as follows.

1. Shut off tractor engine.
2. Remove plastic cover on the left hand drive chain (if fitted with shredder) to access adjuster.
3. Release retaining nuts 1 on bearing.
4. Release locking nut 2 on adjuster and turn back 3-4 full rotations.
5. Repeat for second adjuster.
6. Adjust the chain tension by tightening nut 3 by 2-3 full rotations, making sure to adjust each side by the same amount.
7. Measure the clearance between the floor and the floor chains, repeat step 4 if necessary.
8. Tighten locking nut 2 and retaining nuts 1. Replace drive cover.
9. Run feeder empty and recheck tension.

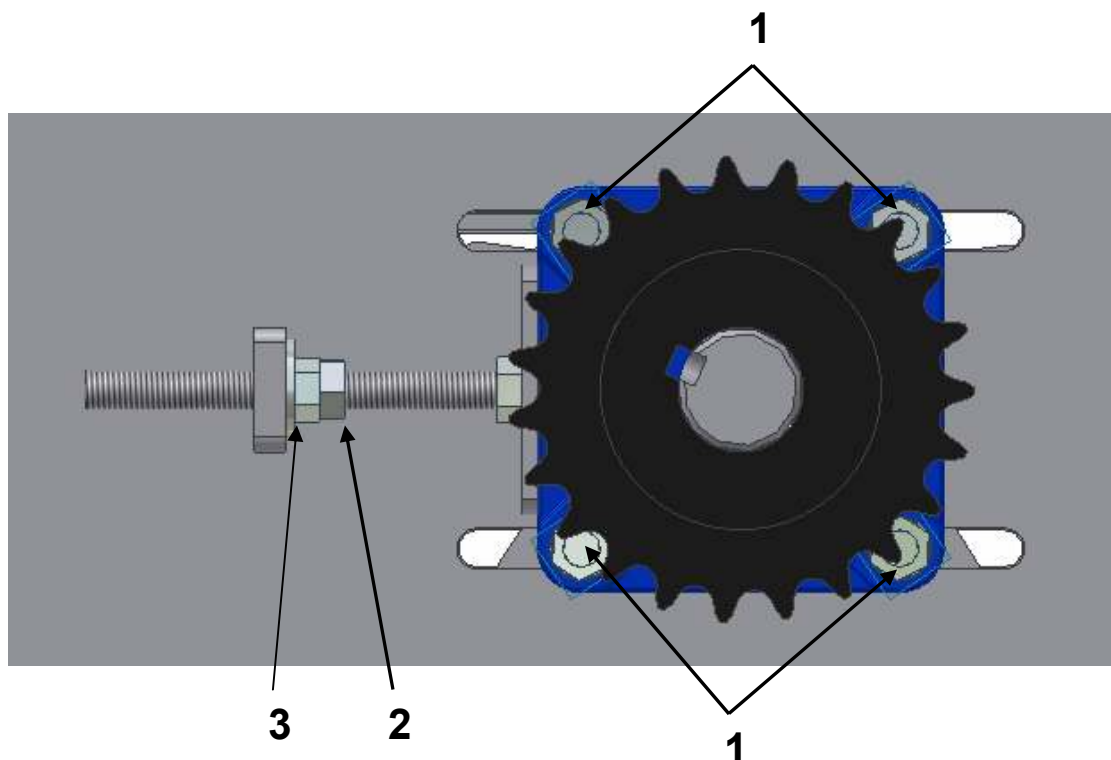

Adjusting the shuttle chain

The shuttle chain should be kept at a tension such that there is between 50 and 100mm of clearance between the underside of the feeder body and the chain at all times, when measured at the lowest point. To adjust the tension of the shuttle chain, follow the instructions below.

1. Shut off the tractor engine
2. Release locking nut1 on adjuster.
3. Repeat for remaining adjusters.
4. Adjust the chain tension by tightening nut 2, making sure to adjust each side by the same amount.
5. Measure the clearance between the body and chain, repeat step 4 if necessary.
6. Tighten locking nut 1.
7. Move the shuttle back and forth with no bales in the chamber and recheck the chain tension.

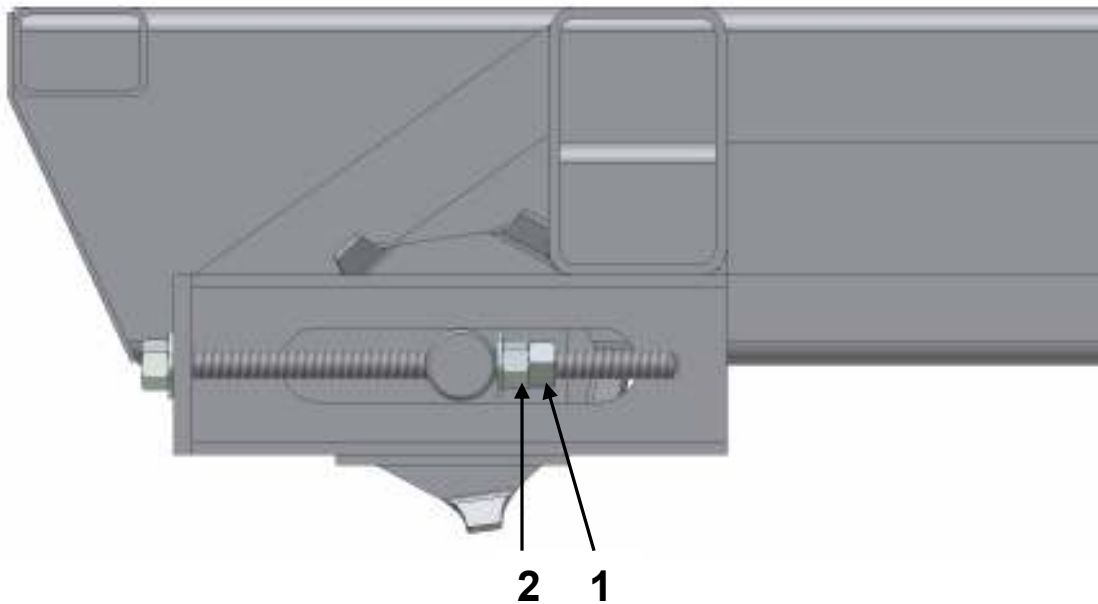

Adjusting the elevator chain

If the distance between the elevator floor and the floor bars exceeds 80-100mm when pulled directly out in the centre of the elevator, adjust the chain as follows;

Fixed elevator

1. Shut off the tractor engine.
2. Release the locking nut 1.
3. Repeat for second adjuster.
4. Adjust the chain tension by tightening nut 2.
5. Measure the chain tension and repeat step 4 if necessary.
6. Tighten locking nut 1.
7. Run feeder empty and recheck tension.

Folding elevator

1. Shut off the tractor engine.
2. Remove cover on input coupling.
3. Follow steps 3-9 under **adjusting the floor chains**.

Spare parts

Before ordering any spare parts, determine the model and serial numbers together with the delivery date and include this information with all orders. The model and serial numbers can be found on the side of the drawbar directly in front of the feed out chamber.

YOUR MACHINE IS

MODEL _____

SERIAL No _____

DATE OF MANUFACTURE _____

DATE OF DELIVERY _____



 AGMECH	
FREE PHONE 0800 422 533	
MODEL No.	
SERIAL No.	
Box 16590 Christchurch New Zealand	

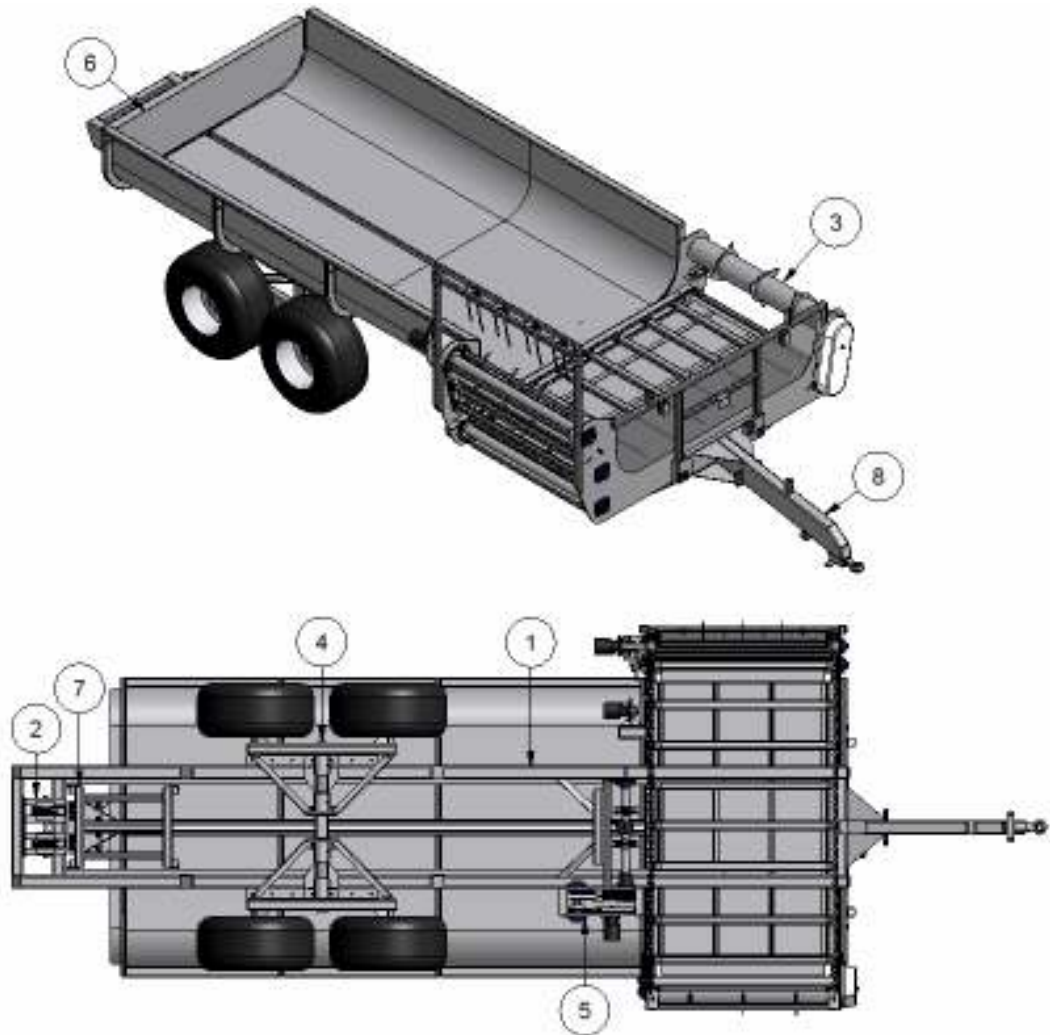

Item	Description
1	Chassis
2	Rear shuttle sprockets
3	Feedout chamber
4	Tandem unit
5	Shuttle drive
6	Pusher
7	Slide frame
8	Drawbar

Troubleshooting

At Agmech we strive to deliver a solution to meet all your daily feed out requirements. The following section has been prepared to help you get the best results from your machine. Do not hesitate to call us if you have a specific problem or alternatively if you have found a way to optimise this feeder, which other farmers may benefit from, let us know and there may be a tasty reward.

- **Bale comes apart in large piles rather than a constant feed row.**
 1. Lower the elevator if fitted with hydraulic folding option.
 2. Try feeding the bale the opposite way, if fitted with bi-directional feed chamber.
 3. Check the hydraulic supply is constant e.g. not accidentally letting the control lever in or out.
 4. For square bales adjust the teaser tines to reduce the gap between the floor and the tines.
 5. Adjust the hydraulic control valve on the front of the feeder, slowing the floor speed will give a more even feed row.
- **Bale does not want to unroll.**
 1. Increase the floor speed using the controller on the front of the feeder.
 2. Try feeding the bale the opposite way.
 3. Use the shredder rotor to break the outer layer of the bale.
 4. Try teasing the bale between the left and right sides to loosen the outer layer.
- **Large build up of material around the shredder rotor.**
 1. Check the clearance between the rotor and the sweeper comb; it should be close to 3mm.
 2. The comb cleans the shredder knives when in reverse.
- **Shredder rotor does not turn.**
 1. Check the hydraulic supply e.g. hoses connected correctly and no leaks.
 2. Check the drive chain under the cover.
 3. Check the coupling on the hydraulic motor.
- **Floor or elevator chains do not move.**
 1. Check the hydraulic supply e.g. hoses connected correctly and no leaks.
 2. Check the coupling on the hydraulic motor.
 3. Check there is no build up of material between chain and guards.

- **Floor or elevator chains come off guide sprockets.**
 1. Foreign material under bars.
 2. Chain needs to be adjusted, refer to maintenance section.

- **Shuttle does not move.**
 1. Check hydraulic supply.
 2. Swap the hydraulic hoses at the tractor.
 3. Check shuttle drive chain assembly.
 4. Check the front drive sprockets and shuttle chain, make sure the chain is securely bolted to the underside of the shuttle frame.
 5. Carefully increase the pressure on the cross line relief valve.

- **No response when using electronic control box.**
 1. Check the power supply to the unit.
 2. Check the wires between the tractor and the feeder for damage.
 3. Check all hydraulic hoses are connected correctly.

Terms and conditions of manufacture and supply

Ownership

Agmech Ltd at all times retains ownership in the goods supplied until payment is made for the goods and for any other goods supplied by Agmech Ltd; and if such goods are sold on their own account or as constituents of other goods by the customer prior to payment to Agmech Ltd then the proceeds of such sale shall be the property of Agmech Ltd.

The customer acknowledges that in the event that default is made in payment for any goods supplied for a period of one month, Agmech Ltd may repossess the goods in their original form or as constituents of other goods and sell the same exercising the full rights as owners of such goods. All losses, costs and expenses incurred in recovering and disposing of the goods is to the cost of and at the liability of the customer.

The customer agrees to indemnify Agmech Ltd for the cost of any litigation arising out of Agmech Ltd acting on any instructions for the customer.

Warranty

Agmech Ltd warrants, for a period of 12 months from the date delivery, its new product and parts to be free from defects in material and workmanship.

Agmech Ltd obligation over this warranty is limited to repair or replacement (at its factory or Agents factory) of any part or parts of the said products which shall be returned to Agmech Ltd with transportation charges prepaid and which Agmech Ltd examination shall disclose to its satisfaction to have been defective.

Agmech Ltd undertakes to remedy with reasonable dispatch, any original defects arising from defects in material or workmanship which under proper and normal conditions of use, are revealed within 12 months from date of delivery. In no case shall Agmech Ltd be liable for the cost of labour and travel incurred in replacing and fitting of the defective parts. Labour and installation charges and costs for work carried out under the terms of this warranty are for the customer's account.

Replacement parts provided under the terms of this warranty are covered for the remainder of the warranty period applicable to the product in which they are installed as if such parts were original components of that product.

For all warranty Agmech Ltd require you to contact them directly; no responsibility will be accepted for any defect, unless a written complaint is first received by Agmech Ltd and we have been given the first priority and ample opportunity to rectify the defect.

Agmech Ltd makes no other warranty, of any kind whatsoever, express or implied; AND ALL IMPLIED WARRANTIES OF MERCHANTABILITY AND FITNESS FOR A PARTICULAR PURPOSE WHICH EXCEED THE ABOVE MENTIONED OBLIGATIONS ARE HEREBY DISCLAIMED BY AGMECH LTD EXCLUDED FROM THIS AGREEMENT.

Agmech Ltd neither assumes nor authorises any person to assume for it, any other obligation in connection with the sale of Agmech's products. This warranty shall not apply to any product nor component thereof which has been repaired or altered outside of an approved factory in any manner so as (Agmech's sole judgment) to affect its serviceability or which has been subject to misuse, negligence, or accident; or to products made by Agmech Ltd which have been operated in a manner contrary to the printed instructions.

Under no circumstances shall Agmech Ltd be liable for loss, damage, cost or repair of consequential damages of any kind in connection with the sale, use and repair of any product purchased from Agmech Ltd.