

AGMECH BALE FEEDER



MANUFACTURERS OF QUALITY MACHINERY

**THIS MANUAL COVERS THE FOLLOWING RANGE OF
AGMECH 2 BALE FEEDERS:**

**DOUBLE CURVE
RS2
SINGLE SHREDDER
DOUBLE SHREDDER
TROUGH FEEDER**

**THIS MANUAL ALSO COVERS THE AGMECH RANGE OF
3 BALE FEEDERS**

OPERATIONAL MANUAL

**Agmech Ltd
PO BOX 16 590, HORNBY
CHRISTCHURCH
NEW ZEALAND**

**PHONE ++64 (03) 344 1322
FAX ++64 (03) 344 5659**



Introduction	3
Double curve	5
RS2	5
Single shredder	6
Twin shredder	6
Trough feeder	7
3 bale feeder	7
Safety	8
Attaching to the tractor	11
Loading the feeder	13
Feeding out	15
Round bales	15
Square bales	15
Trough feeder	16
3 Bale feeder	16
Maintenance	17
Before daily operation	17
Every x hours of operation	18
Every six months or before storage	23
Adjusting the floor chains	24
Optional extras	26
Spare Parts	27
Terms and conditions of manufacture and supply	30



Introduction

Thank you for considering Agmech for your 2 bale feed-out requirements, this is one of an extensive range of tried and tested machines sold throughout New Zealand. Our 2 Bale feeder range is by far the biggest range offered by any manufacturer as we endeavour to offer you a range of feeders to handle the variation that you face everyday when feeding out bales that seem to change continuously. These feeders have been developed out of years of working with both farmers and our engineers, so you can rest assured knowing you have invested in the best there is to offer.

What we have aimed to achieve is -

- a functional machine that exceeds your expectation in the field.
- that the engineering, design and ascetics of the machine prove to give you maximum longevity.
- that the price ensures that the unit is competitive whilst considering spec for spec.
- that the optional equipment ensures all customers requirements are covered.

The Agmech range of 2 bale feeders is able to offer you a solution to any bale feed-out problem. Whether spending a lot or a little we cater for all requirements. Rest assured that all machines are robust and built to last with an expectation that will see your feeder here for the long haul.

All Agmech feeders have the ability to feed both ways, this is ideal especially for sheep & deer. The 2" pitch chain with welded RHS floor bar not only facilitates bi-directional feed, it also allows for a constant centre of gravity, which dramatically reduces the risk of roll over.

All of the 2 bale trailing models are uniquely self loading. The forks have been designed to pierce the bale (no matter what the weight) with the tines OFF the ground, ensuring no breakages of tines as well as easing the ability to remove plastic and net-wrap. The loading tine is mounted to a heavy duty knuckle which allow the tine to 'pull out' once loaded, all this is driven by the 4" loading ram which allows for older tractor to have enough oil to load heavy bales. The self loading forks allow for a 2nd bale to be transported to the waiting stock.

All drives consist of 40mm bearings and shafts, whilst the fully welded 152 x 76 section RHS chassis is the basis of the heavy duty construction. The unique straight drawbar allows for maximum turning circle and is fitted with a forged 40mm eye and 60mm height adjustment jack. The full steel floor complements the design as do features such as 2 wire hydraulic hoses, high torque hydraulic motor and large axle with flotation wheels and an ability to fit up to 400 x 15.5 wheels for really wet going.



The tease shredders (if fitted) are specially designed to run at 25% faster so they naturally accelerate the material into a well presented air-rated row. These rotas are fitted with a special anti blocking comb that sweeps the rota clean as it turns.

With a model for every bale type is pays to choose Agmech, we will show you how to buy smart, work well and give you piece of mind and longevity with the added investment of an excellent trade in value if your circumstances change and to need to trade up to an alternative feed type.

Double curve

This is our base line model, with high curves on both sides of the feed out chamber, ideal for chopped round bales. The feeder allows for bi-directional feeding to suit any requirements.

RS2

This model is similar to the double curve, with a set of additional teaser tines fitted on adjustable frames to allow square bales to be feed easily with the ability to feed round bales also.



Single shredder

This model has an additional tease rotor in place of the high curve on one side of the feeder. The shredder is designed to run at 25% faster than the floor chains to tease tight bales apart, giving a fluffy feed row which allows a good flow of air through the material. The combination of the high curve and single shredder allows both tight and chopped bales to be feed with ease. The additional sweeper comb on the shredder cleans the rotor, preventing a build up of material.



Twin shredder

The twin shredder has two tease rotors fitted for feeding tight long chopped bales which tend to bind together. The shredder is designed to run at 25% faster than the floor chains to tease tight bales apart, giving a fluffy feed row which allows a good flow of air through the material.



Trough feeder

The trough feeder has an extension specifically for feeding into troughs. The trough feeder can be fitted with either a high curve or single shredder to meet any feed requirements or bale types. The trough feeder is available with a fixed extension or a hydraulically folding extension to reduce the transport width of the feeder.

3 bale feeder

The 3 bale feeder range is available with any of the feeder chambers available in the 2 bale range. The 3 bale feeders have an extended chassis which allows a third bale to be transported directly behind the feed chamber while one bale remains on the loading forks the same as the 2 bale range of feeders.



Safety

Before operation of this machine, please ensure yourself and all additional operators are trained in the correct operating procedures and aware of all safety requirements and potential hazards.

General Safety Precautions:

1. Take all practical steps to ensure the safety of yourself and others.
2. Where possible, read and understand the applicable Health and Safety regulations for your area.
3. Before attempting to operate the machine the operator must be fully trained and familiar with the safe working limits, controls and operator instructions as detailed in this manual.
4. Ensure all guards remain in place during operation.
5. Keep clear of all moving parts and be aware of pinch points.
6. Do not perform any maintenance or repairs without shutting off the tractor beforehand.
7. Exercise caution whenever working with hydraulics.
8. You must eliminate if practicable, or otherwise isolate or minimise all significant hazards and report to your Safety Officer or Supervisor IMMEDIATELY every hazard or safety problem that you notice.
9. If you witness an accident or incident where someone was or could have been injured, you MUST report it as soon as you can.
10. For serious accidents the entire accident scene must not be interfered with until authorised by an inspector from the appropriate Health and Safety Authority, unless absolutely necessary to save life, property, etc.
11. If you received an injury while at work it MUST be reported immediately to your Supervisor or Safety Officer. The accident will be recorded on either a form for Record of Accident/Serious Harm or a form for Minor Accident or Near Miss Report. If a work injury is not reported on the day the injury occurs it may not be accepted as a work related injury and which could affect your work accident insurance.

Specific safety hazards:

Failure to comply with the following safety requirements could result in serious personal injury or loss of life.

1. When attaching the feeder to the tractor, nobody must be in the area between the tractor and the feeder unless the tractor is in neutral with the park brake securely on.
2. Do not remove the drawbar pin without chocks under the wheels and the jack down.
3. No person may be permitted to ride on the machine.
4. Keep clear of loading frame at all times during loading.
5. The guards on each drive chain and the drive coupling must remain in place at all times during operation of the feeder. The feeder must not be operated without these guards in place.
6. Keep clear of the drive and floor chains at all times during operation. Shut the tractor engine off before making any adjustments to the feeder.
7. Keep clear of shredder rotors (if fitted) at all times during operation.
8. Keep clear of hydraulic ram and folding extension on trough feeder.
9. Under no circumstance shall a person be underneath a bale or part of the feeder without suitable supports to prevent unintended lowering of the feeder.

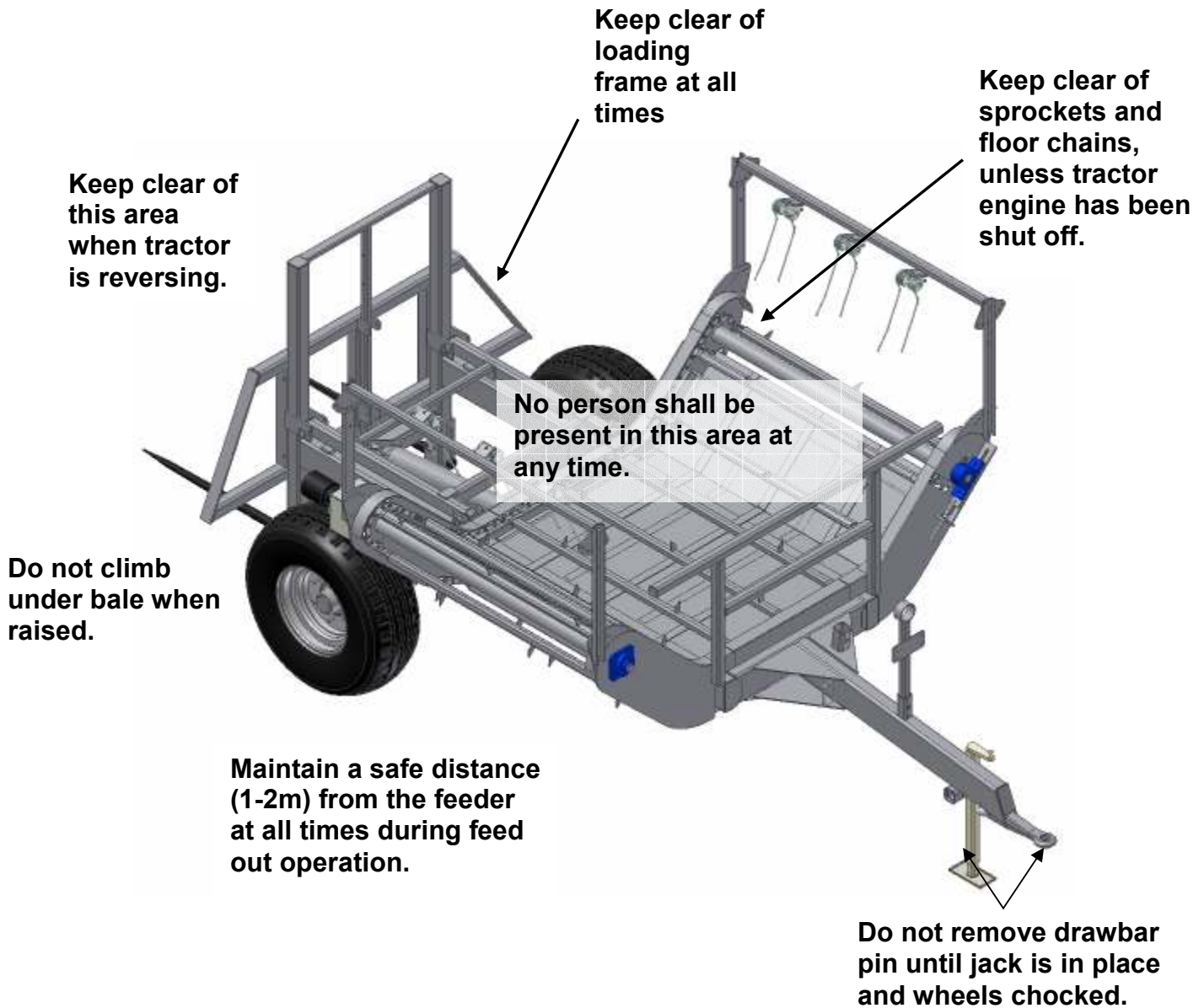

Attaching to the tractor

Once the contents of this manual have been read and understood, familiarize yourself with the feeder and each of the components before selecting a tractor.

When selecting a tractor to operate the feeder please consider the following;

1. The terrain and conditions you will be operating in.
2. The tare weight of the feeder you are using
 - 2 bale double curve: 940kgs
 - 2 bale RS2: 880kgs
 - 2 bale single shredder: 1020kgs
 - 2 bale twin shredder: 1100kgs
 - 2 bale trough feeder: 1170kgs
 - 3 bale feeder: 1480kgs (depending on options)
3. The weight of the bales you are about to feed out
 - Approximate payload:
 - 800kgs per silage bale
 - 500kgs per hay bale
4. The availability of two sets of double acting hydraulic outlets, 3 required for folding trough extension, otherwise a hydraulic diverter may be required. Minimum 32 litres/minute.
5. The tare weight of the tractor.
6. Whether the towing tractor is fitted with foot pedal braking.
7. Whether you will be travelling on a public highway and therefore the local regulations you will be required to follow.

All of the above factors are relevant to ensure safe and successful operation of the feeder.

Connecting up the feeder

The bale feeder will be fitted with a fixed tow eye as standard or a swivel/variable height tow eye as optional. These tow eyes are rated to European standard of origin and comply with all relevant T.U.V. and D.I.N. compliance codes.

Important: Please ensure that you have studied the tractor manufacturer recommended drawbar load rating and the feeder is not going to exceed this.

Assuming that the tractor is fitted with the standard double clevis type drawbar then it is good practice to ensure that the tractor and feeder are permanently attached by fitting cross over safety chains (this may be enforced in some countries), these are not supplied as standard but can be purchased from the manufacturer.

It is also favourable to fit a spacer bush (if required) between the tow eye and drawbar pin, this will prevent un-necessary drawbar pin wear as well as increasing operator comfort by eliminating fore and aft banging. These bushes are not supplied as standard but can be purchased from the manufacturer.

For attaching the feeder to a standard double clevis drawbar;

1. Set the height of the feeder drawbar to match the selected tractor using the supplied jack on the feeder.
2. Make sure you have a suitable drawbar pin and lynch pin/R-clip to fit pin.
3. With the tractor drawbar in the central position, reverse up to the feeder until the drawbar and feeder tow eye overlap.
4. Fit the drawbar pin and spacer bush if required, lock the drawbar pin in place using a pin or clip to prevent the drawbar pin from jumping out during operation.
5. Fit the safety chains between the tractor and feeder drawbar, ensuring there is sufficient slack in each chain when under full steering lock.
6. Wind the jack fully in, pull the pin holding the jack to the drawbar and transfer the jack to the transport position in front of the bale chamber. Ensure you lock the jack in place using the pin before moving off.
7. Connect up the hydraulic hoses to the outlets on the tractor, it is often preferred to connect the two hoses controlling the feed out chamber to the number 1 remote and then control the loading operation using the number 2 remote. Make sure each coupling is clean before connecting.

Loading the feeder

The Agmech 2 and 3 bale feeders are loaded using a set of integral forks attached to the rear of the feeder.

1. Reverse the feeder towards the desired bale.
2. Lower the loading forks fully.
3. Remove the plastic silage wrap together with the net wrap from the bale, disposing of the waste responsibly. The net wrap can be removed from the bale while on the loading forks if desired.
4. Reverse the loading tines into the bale, try to keep as central and square to the bale as possible.



5. Once the bale is completely on the forks, raise the loading forks to transfer the bale to the feed out chamber.



6. The second bale can then be transported on the rear forks by repeating steps 2-5, lifting the bale till it is nearly vertical but clear of the bale already in the chamber.
7. The third bale (3 bale feeders only) can be loaded by repeating step 6 after the second bale has been transferred to the transport platform directly behind the feed out chamber.



Feeding out

All Agmech bale feeders offer the ability to feed out either side, to meet any specific feed out requirements. The feed out operation is controlled by the single hydraulic outlet, which can be set in detent for continuous feeding or alternatively controlled by the operator for a start – stop operation.

Important: it is advised that any net wrap or baler twine is removed prior to feed out as it can find its way into bearing seals and sprockets causing damage.

Round bales

- For dense row feeding- feed the bale out the same way it was rolled up, which can be determined by either looking at the bale before loading or once feeding has commenced.
- For light row feeding-feed the bale against the way it was rolled up to give wafers of material.
- The size of the feed row can be controlled using the first hydraulic outlet- the lever fully back with high tractor revs will give a heavy feed row meanwhile if the tractor revs are low and the hydraulic lever is only partially back you will achieve a light feed row.
- The tease shredders (if fitted) accelerate the material to provide a row which sits above the ground, allowing a good flow of air through the material, making it more appealing for livestock.
- Staggered feeding -can is achieved by alternating the feeding pattern from left to right. This is ideal for sheep as it prevents them from running on the crop as they will now tend to circle.
- Once the first bale has been feed out, the wrap/ twine can be removed from the second bale and transferred to the feed out chamber using the loading forks. Remember to remove the loading forks from the bale before commencing feedout.

Square bales

- The teaser tines on each side of the bale feeder can be adjusted to suit the type of square bale.
- The size of the row can be varied by adjusting the hydraulic flow delivered to the feeder.
- Staggered feeding can be achieved by alternating the feeding pattern from left to right. This is ideal for sheep as it prevents them from running on the crop as they will now tend to circle.
- Once the first bale has been feed out, the wrap/ twine can be removed from the second bale and transferred to the feed out chamber using the loading forks. Remember to remove the loading forks from the bale before commencing feedout.

Trough feeder

- If fitted with the hydraulic folding extension, lower the extension fully down, using the hydraulic outlet the hoses from the ram are connected into.
- Raise the feeder so the extension is clear of the trough.
- For best results position the tractor so the end of the extension is above the centre of the trough.
- Begin feeding, controlling the size of the feed row using the first hydraulic outlet- the lever fully back with high tractor revs will give a heavy feed row meanwhile if the tractor revs are low and the hydraulic lever is only partially back you will achieve a light feed row.
- Drive forward at a constant speed, keeping parallel to the side of the trough.
- Once finished feeding out, lift the extension up using the same hydraulic outlet used to lower.
- Once the first bale has been feed out, the wrap/ twine can be removed from the second bale and transferred to the feed out chamber using the loading forks. Remember to remove the loading forks from the bale before commencing feedout.

3 Bale feeder

- The feeding operation can be controlled as above, depending on the type of feed chamber fitted to the machine.
- Before the second bale can be transferred to the feed chamber, the rear section of the loading frame must be locked.
- From the transport position, lower the rear bale so it is at an angle of about 45°.
- The two locking pins must then be put through the frame; this is easily done with the attached lever on the side of the feeder.
- The loading frame can then be raised up, transferring the second bale to the chamber.
- Before the third bale can be transferred to the feed chamber the locking pins must be removed. The frame is then lifted again and the rollers transfer the bale to the feeder chamber.

Maintenance

The following guidelines if followed correctly will allow for many years of successful operation.

Please check all Nuts & bolts prior to use, then after 8 hours of use and finally after 100 hours of operation, this will ensure everything will remain tight. Then seasonal servicing will be sufficient to maintain the feeder.

Greasing intervals have been based on a standard hand lever grease gun. **Do not use an air powered grease gun.** General multipurpose grease is sufficient although the bearings would benefit from dedicated bearing grease.

Before daily operation

1. Visually inspect all parts of the feeder for wear or damage.



2. Make sure there is no build up of material around sprockets or bearings.
3. Check the tyres for wear damage and pressure.

Every x hours of operation

- Grease the main bearings in the feed out chamber. One pump per bearing is sufficient.

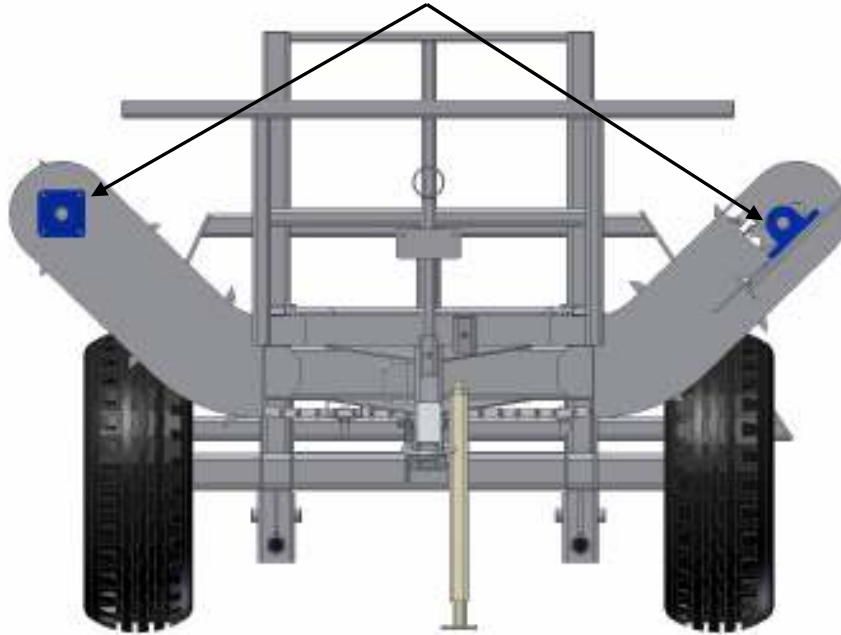

	Feeder model					
	Double curve	RS	Single shredder	Twin shredder	Trough feeder	Multi
Number of bearings	6	6	6	8	6	10

- Lubricate the drive and floor chains with and 50:50 mix of oil and diesel, easily applied with a paint brush. The drive chains can be easily accessed by removing the plastic cover(s) on the front of the feeder.

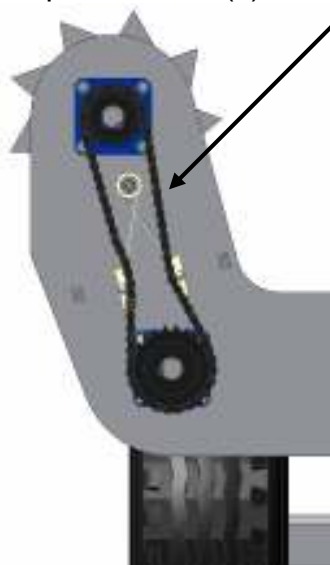

6. Check the tension of the floor chains by measuring the clearance between the underside of the feeder floor and the floor chains. This should not be greater than 100 mm. Check the drive chains are under tension.

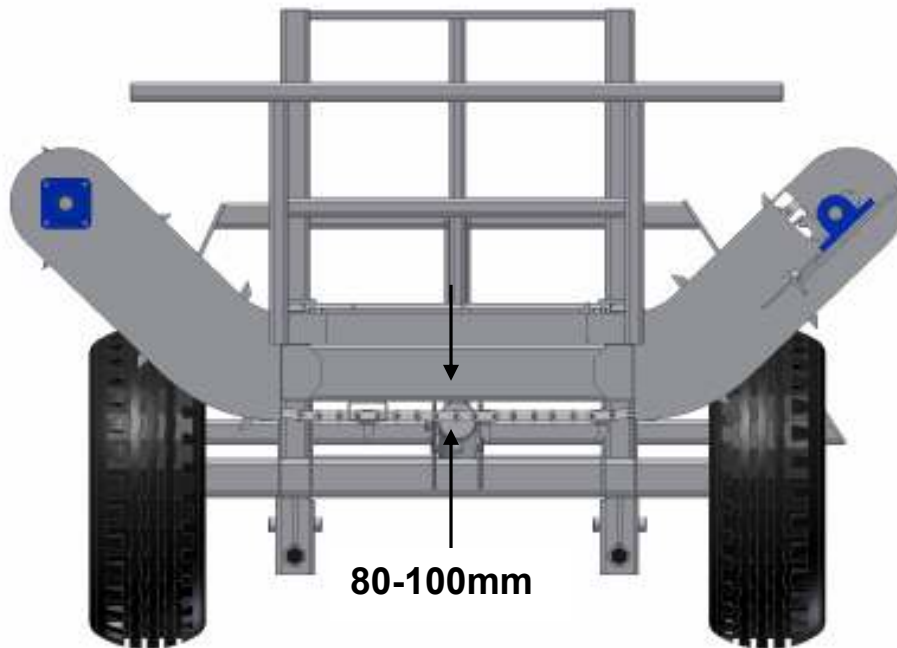

7. Check the loading tines are secure.
8. Check the hydraulic motor is tight on its housing and there are no leaks in the hoses.



9. Grease and check for excessive movement in the swivel tow eye if fitted.
10. Grease the jack if fitted with grease nipples.

11. Grease the wheel bearings if fitted with grease nipples.
12. Check for excessive movement in the pin/bushes (1) of the hydraulic cylinder. When the machine is being stored for long periods of time the ram spear (2) should be greased to prevent corrosion.
13. Check for excessive movement and grease all the pivot points on the loading frame;
 - 2 on hydraulic ram
 - 2 pivots on the main frame.
 - 2 pivots between lifting arms and frame.
 - 2 pivots between loading tines and frame.
 - 2 pivots mid-lifting arm (*3 bale only*)

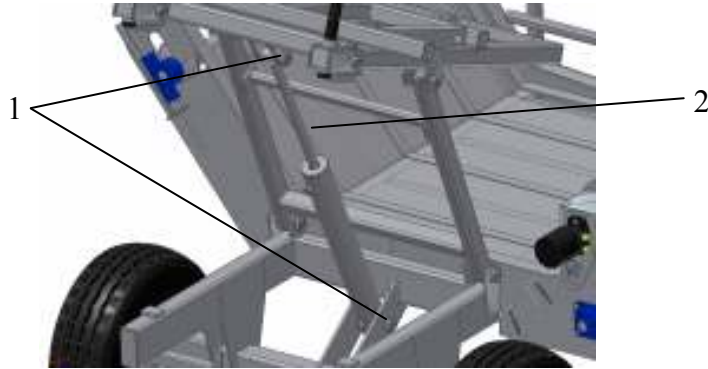

GREASE POINTS - PIVOTS

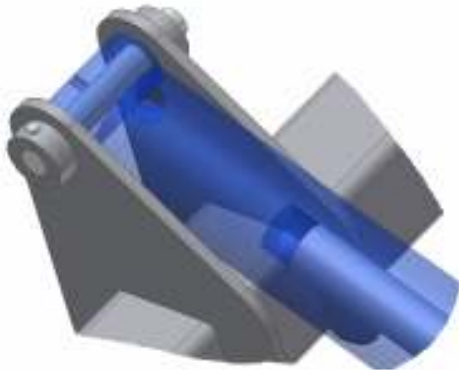

GREASE – BOTH ENDS OF RAM



GREASE – FRAME PIVOTS

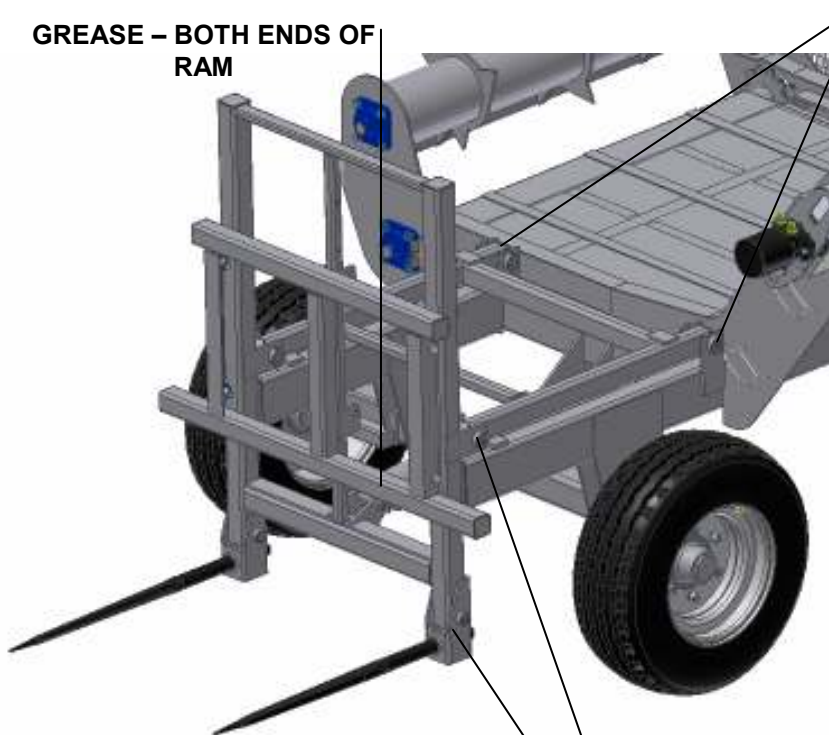

GREASE – FORK PIVOTS



14. Folding trough feeder: Grease the pivot points on the hydraulic ram and the main pivot shaft for the extension. (4 grease nipples)

Every six months or before storage

15. Inspect and grease the main bearings in the feed out chamber. One pump per bearing is sufficient. (4)
16. Lubricate the drive and floor chains with and 50:50 mix of oil and diesel, easily applied with a paint brush. The drive chains can be easily accessed by removing the plastic cover(s) on the rear of the feeder. (5)
17. Check the tension of the floor chains by measuring the clearance between the underside of the feeder floor and the floor chains. This should not be greater than 100 mm. Check the drive chains are under tension. (6)
18. Check the loading tines are secure.
19. Visually inspect all parts of the feeder.
20. Check the hydraulic motor is tight on its housing and there are no leaks in the hoses.
21. Check the free play in the wheel bearings.
22. Check the condition of the input couplings.

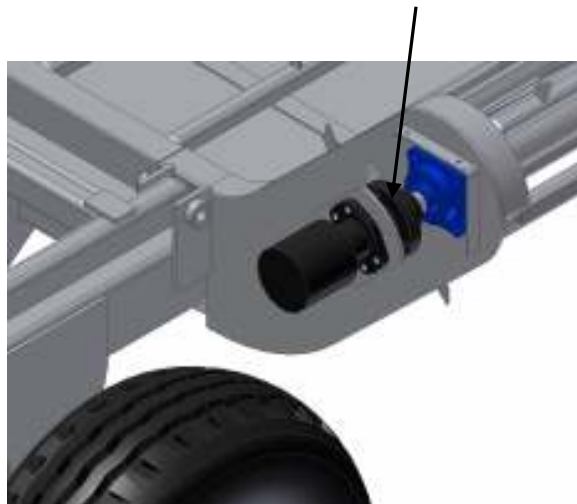

23. If storing for long periods of time, it is advisable to jack the rear of the feeder up, so the wheels are free of the ground and support the main frame with suitable blocks of wood.

Adjusting the floor chains

Double curve and RS2

If the distance between the underside of the floor and the floor chains exceeds 80-100mm adjust the floor chains as follows.

1. Shut off tractor engine.
2. Release retaining nuts 1 on bearing.
3. Release locking nut 3 on adjuster and turn back 3-4 full rotations.
4. Repeat steps 2 and 3 for second adjuster.
5. Adjust the chain tension by tightening locking nut 2 by 2-3 full rotations, making sure to adjust each side by the same amount.
6. Measure the clearance between the floor and the floor chains, repeat step 5 if necessary.
7. Tighten locking nut 3 and retaining nuts 1.

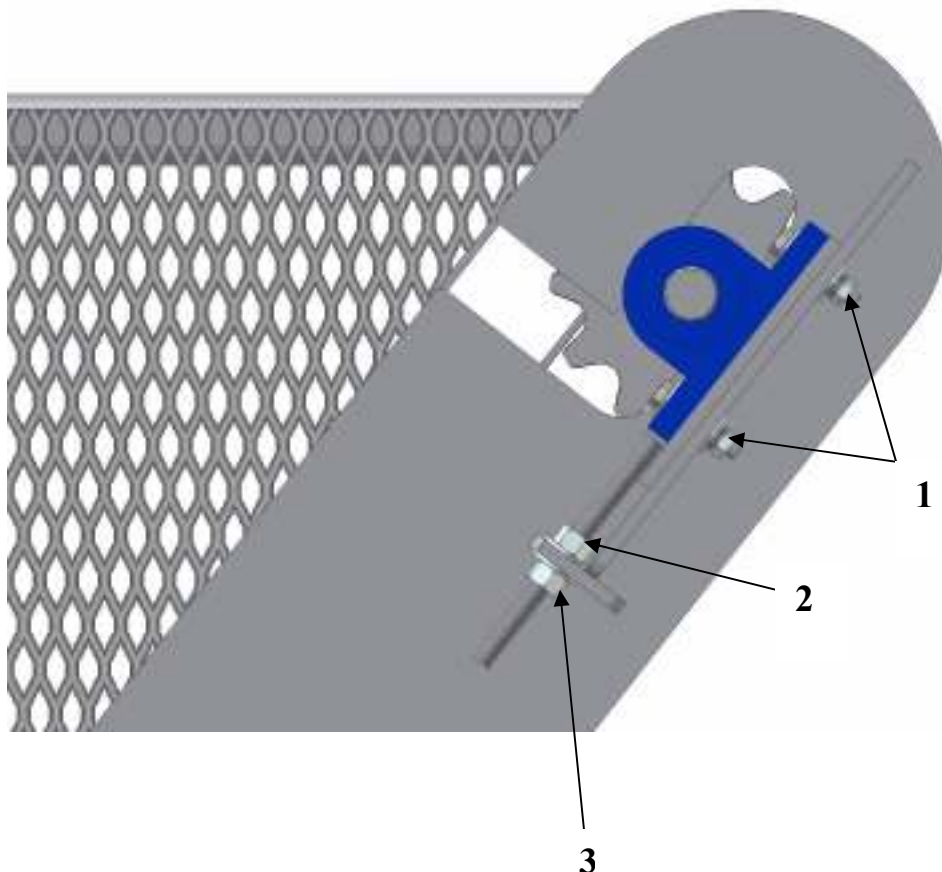

Single, twin shredder and trough feeder

If the distance between the underside of the floor and the floor chains exceeds 80-100mm adjust the floor chains as follows.

1. Shut off tractor engine.
2. Remove plastic cover on the left hand drive chain to access adjuster on twin shredder models.
3. Release retaining nuts 1 on bearing.
4. Release locking nut 2 on adjuster and turn back 3-4 full rotations.
5. Repeat for second adjuster.
6. Adjust the chain tension by tightening locking nut 3 by 2-3 full rotations, making sure to adjust each side by the same amount.
7. Measure the clearance between the floor and the floor chains, repeat step 4 if necessary.
8. Tighten locking nut 2 and retaining nuts 1.
9. Run feeder empty and recheck tension.

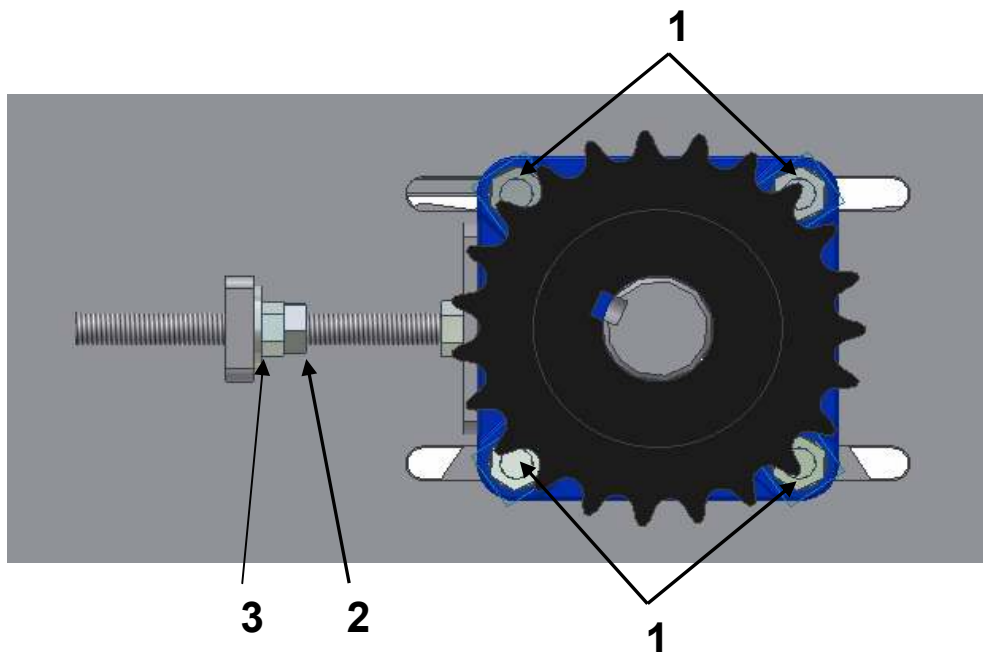



Optional extras

To ensure your Agmech feeder is able to meet all your feed out requirements, we offer a range of standard optional extras together with the ability to custom build if required.

- Large flotation tyres: ideal for wet soft conditions.
- Twine box: Stores all your twine and wrap on the feeder rather than inside your cab.
- Swivel tow eye: Allows the feeder to oscillate independently of the tractor in undulating areas.
- Hydraulic diverter valves: Ideal for older tractors with only single hydraulic remotes.

Spare Parts

Before ordering any spare parts, determine the model and serial numbers together with the delivery date and include this information with all orders. The model and serial numbers can be found on the inside of the frame at the front of the machine.

YOUR MACHINE IS

MODEL _____

SERIAL No _____

DATE OF MANUFACTURE _____

DATE OF DELIVERY _____



 AGMECH	
FREE PHONE 0800 422 533	
MODEL No.	
SERIAL No.	
Box 16590 Christchurch New Zealand	

Troubleshooting

At Agmech we strive to deliver a solution to meet all your daily feed out requirements. The following section has been prepared to help you get the best results from your machine. Do not hesitate to call us if you have a specific problem or alternatively if you have found a way to optimise this feeder, which other farmers may benefit from, let us know and there may be a tasty reward.

Bale comes apart in large piles rather than a constant feed row.

1. Try feeding the bale the opposite way.
2. Check the hydraulic supply is constant e.g. not accidentally letting the control lever in or out.
3. For square bales (RS2) adjust the teaser tines to reduce the gap between the floor and the tines.

Bale does not want to unroll.

1. Check loading tines have been retracted from bale.
2. Try feeding the bale the opposite way.
3. Try teasing the bale between the left and right sides to loosen the outer layer.

Large build up of material around the shredder rotors

1. Check the clearance between the rotor and the sweeper comb, it should be close to 3mm.
2. The comb cleans the shredder knives when in reverse.

Shredder rotor does not turn.

1. Check the hydraulic supply e.g. hoses connected correctly and no leaks.
2. Check the drive chain under the cover.
3. Check the coupling on the hydraulic motor.

Floor chains do not move.

1. Check the hydraulic supply e.g. hoses connected correctly and no leaks.
2. Check the drive chain under the cover.
3. Check the coupling on the hydraulic motor.
4. Check there is no build up of material between chain and guards.

Floor chains come off guide sprockets.

1. Foreign material under floor bars or sprockets worn.
2. Chain needs to be adjusted, refer to maintenance section.

Rear loading forks do not want to raise bale.

1. Check the hydraulic supply e.g. hoses connected correctly and no leaks.
2. Check the hydraulic ram for scoring on the spear and oil leaks.
3. Check all the pivot pins.

Bale does not transfer to the feeder chamber fully.

1. Make sure to reverse fully into the bale.
2. Check the sliding tray moves freely.
3. Reduce the raising speed of the table once above horizontal, allowing the table to slide fully forward.
4. Check the rollers spin freely (3 bale feeders only).
5. Make sure the locking pins are in place (3 bale feeders only)



Terms and conditions of manufacture and supply

Ownership

Agmech Ltd at all times retains ownership in the goods supplied until payment is made for the goods and for any other goods supplied by Agmech Ltd; and if such goods are sold on their own account or as constituents of other goods by the customer prior to payment to Agmech Ltd then the proceeds of such sale shall be the property of Agmech Ltd.

The customer acknowledges that in the event that default is made in payment for any goods supplied for a period of one month, Agmech Ltd may repossess the goods in their original form or as constituents of other goods and sell the same exercising the full rights as owners of such goods. All losses, costs and expenses incurred in recovering and disposing of the goods is to the cost of and at the liability of the customer.

The customer agrees to indemnify Agmech Ltd for the cost of any litigation arising out of Agmech Ltd acting on any instructions for the customer.

Warranty

Agmech Ltd warrants, for a period of 12 months from the date delivery, its new product and parts to be free from defects in material and workmanship.

Agmech Ltd obligation over this warranty is limited to repair or replacement (at its factory or Agents factory) of any part or parts of the said products which shall be returned to Agmech Ltd with transportation charges prepaid and which Agmech Ltd examination shall disclose to its satisfaction to have been defective.

Agmech Ltd undertakes to remedy with reasonable dispatch, any original defects arising from defects in material or workmanship which under proper and normal conditions of use, are revealed within 12 months from date of delivery. In no case shall Agmech Ltd be liable for the cost of labour and travel incurred in replacing and fitting of the defective parts. Labour and installation charges and costs for work carried out under the terms of this warranty are for the customer's account.

Replacement parts provided under the terms of this warranty are covered for the remainder of the warranty period applicable to the product in which they are installed as if such parts were original components of that product.

For all warranty Agmech Ltd require you to contact them directly; no responsibility will be accepted for any defect, unless a written complaint is first received by Agmech Ltd and we have been given the first priority and ample opportunity to rectify the defect.

Agmech Ltd makes no other warranty, of any kind whatsoever, express or implied; AND ALL IMPLIED WARRANTIES OF MERCHANTABILITY AND FITNESS FOR A PARTICULAR PURPOSE WHICH EXCEED THE ABOVE MENTIONED OBLIGATIONS ARE HEREBY DISCLAIMED BY AGMECH LTD EXCLUDED FROM THIS AGREEMENT.

Agmech Ltd neither assumes nor authorises any person to assume for it, any other obligation in connection with the sale of Agmech's products. This warranty shall not apply to any product nor component thereof which has been repaired or altered outside of an approved factory in any manner so as (Agmech's sole judgment) to affect its serviceability or which has been subject to misuse, negligence, or accident; or to products made by Agmech Ltd which have been operated in a manner contrary to the printed instructions.

Under no circumstances shall Agmech Ltd be liable for loss, damage, cost or repair of consequential damages of any kind in connection with the sale, use and repair of any product purchased from Agmech Ltd.